

# Bullhorn Arms

Bullhorn Arms are engineered and manufactured of Aluminum Alloy 6063 components and are heat-treated after weld to a T6 temper. Stainless Steel Mounting Hardware is included. Standard Bullhorns are constructed of 2" NPS (2-3/8" O.D.) Schedule 40 Pipe. Center Hub information is noted. Custom designs including varying Pipe Arm diameters, Arm dimensions, and Center Hub sizes to accommodate varying Tenons are available.

Please contact Big Shine LED for more information.

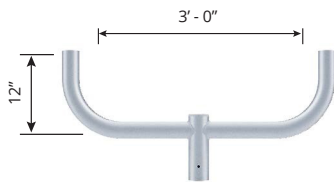

**77255**

Double Bullhorn Arm - 180°

Model No.	Description	Pipe Arm Diameter	Use With Tenon Size	Bracket EPA
77255	Double Bullhorn - 180°	2" NPS (2.375" O.D)	2" NPS (2.375" O.D)	0.90 ft <sup>2</sup>
77282	Triple Bullhorn - 180°	2" NPS (2.375" O.D)	2" NPS (2.375" O.D)	1.60 ft <sup>2</sup>
77283	Quad Bullhorn - 180°	2" NPS (2.375" O.D)	2.5" NPS (2.875" O.D)	2.14 ft <sup>2</sup>
77280	Triple Bullhorn - 120°	2" NPS (2.375" O.D)	2.5" NPS (2.875" O.D)	1.55 ft <sup>2</sup> (Shielded)
77281	Quad Bullhorn - 90°	2" NPS (2.375" O.D)	2.5" NPS (2.875" O.D)	2.04 ft <sup>2</sup> (Shielded)

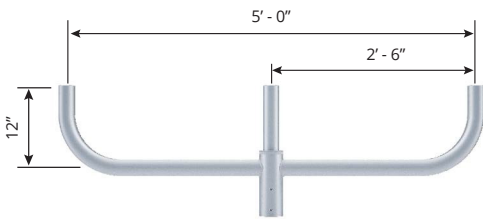

**77282**

Triple Bullhorn Arm - 180°

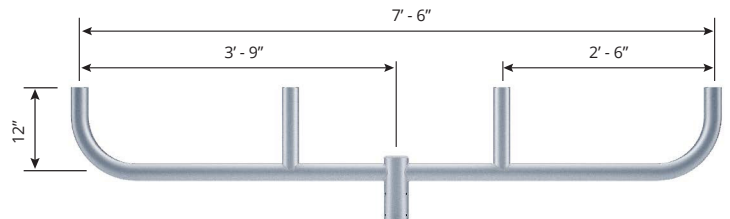

**77283**

Quad Bullhorn Arm - 180°

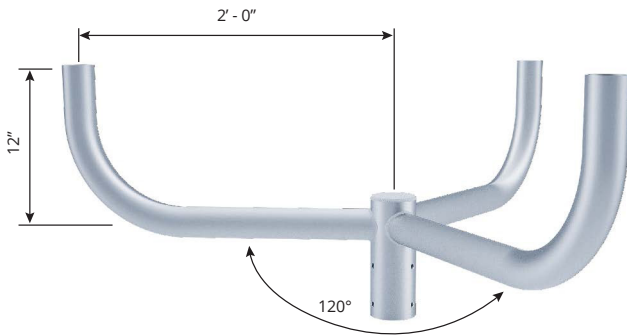

**77280**

Triple Bullhorn Arm - 120°

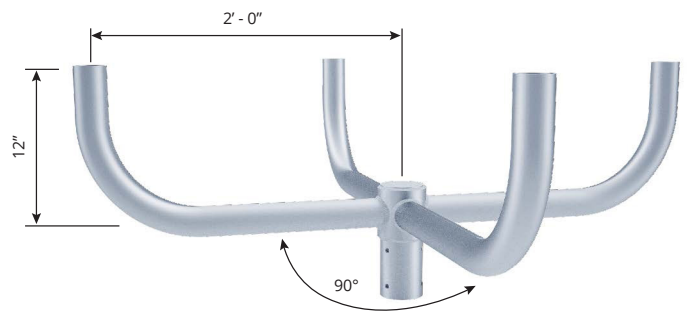

**77281**

Quad Bullhorn Arm - 90°