

DELTA Explosion Proof

Big Shine's Delta explosion-proof luminaire is not only able to withstand various hazardous chemicals, but was designed with a temperature-resistant pressed glass and aluminum housing that extends the breadth of its applications.

Delta is certified for the following hazardous area classifications: Class I, Division 1, Groups B, C, and D, as well as Class II, Division 1, Groups E, F, and G.

APPLICATIONS

Commercial: Marine Loading Terminals, Gas Stations

Industrial: Petrochemical Processing Facilities, Chemical Processing Facilities, Storage Facilities, Manufacturing Plants, etc.



DIMENSIONS

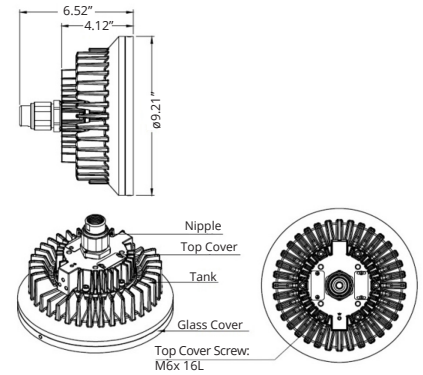

MODEL OPTIONS

Mftr	Fixture Type	Wattage	Name	Driver	Chip	Color	Beam Angle
BSL BIG SHINE LED	EP Explosion Proof	60W, 80W	DLT	GN Generic	ES Epistar	3000K-5000K	110°

TECHNICAL SPECIFICATIONS

	60W	80W
Lumens	6000	8000
Efficacy	100	100
CRI	70	70
Voltage Input	277V	277V
Amperage	0.22	0.29
Hertz	50-60Hz	50-60Hz
Dimmability	Non-Dimmable	Non-Dimmable
Operating Temp.	-4~104°F*	-4~104°F*
IP Rating	IP67	IP67
IK Level	IK07	IK07
Lifetime	50,000 hrs	50,000 hrs

FIELD & BEAM ANGLES

MODEL	Beam	Height vs. Illuminance (Ft vs Lux)		
	Angle	9.8 ft	19.7 ft	29.5 ft
BSL-EP60-DLT-GNES-5000K-110	110	245.5	61.4	27.3
BSL-EP80-DLT-GNES-5000K-110	110	317.8	79.4	35.3

PHOTOMETRICS

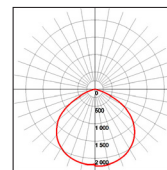

60W-5000K-60°

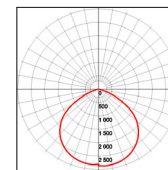

80W-5000K-110°

*Models operating up to 220°F available upon customer request.

MOUNTING OPTION

Suspended Mount, Swivel Mount

COLOR OPTIONS



*Customized colors available upon RAL request. MOQ applies.

